

Templates for Toffoli Network Synthesis

Dmitri Maslov
Faculty of Computer Science
University of New Brunswick
Fredericton, NB, E3B 5A3
Canada
dmaslov@unb.ca

Gerhard W. Dueck
Faculty of Computer Science
University of New Brunswick
Fredericton, NB, E3B 5A3
Canada
gdueck@unb.ca

D. Michael Miller
Dept. of Computer Science
University of Victoria
Victoria, BC, V8W 3P6
Canada
mmiller@csr.uvic.ca

ABSTRACT

Reversible logic functions can be realized as networks of Toffoli gates. The synthesis of Toffoli networks can be divided into two steps. First, find a network that realizes the desired function. Second, transform the network such that it uses fewer gates, while realizing the same function. This paper addresses the second step. Transformations are accomplished via template matching. The basis for a template is a network with m gates that realizes the identity function. If a sequence in the network to be synthesized matches more than half of a template, then a transformation reducing the gate count can be applied. All templates for $m \leq 7$ are described in this paper.

Keywords

Reversible Logic, Quantum Circuits, Templates, Minimization

1. INTRODUCTION

Reversible logic is an emerging research area. Interest in reversible logic is sparked by its applications in quantum computing, low-power CMOS, nanotechnology, and optical computing. The synthesis of reversible circuits differs significantly from synthesis using traditional irreversible gates. Two restrictions are added for reversible networks, namely fan-outs and back-feeds are not allowed. The only possible structure for a reversible network is a cascade of reversible gates. The most frequently used gates are the Toffoli gate [13] and the Fredkin gate [4]. The Toffoli gate inverts a single bit if the AND of a set of control lines is 1. The Fredkin gate interchanges two bits if the AND of a set of control lines is 1. The formal definition is given in Section 2.

Only a few synthesis methods have been proposed for reversible logic. Suggested methods include: using Toffoli gates to implement an ESOP (EXOR sum-of-products) [10], exhaustive enumeration [12], heuristic methods that iteratively make the function simpler (simplicity is measured by

the Hamming distance [2] or by spectral means [8]), and transformation based synthesis [5], among others. Some methods use excessive search time, others are not guaranteed to converge, and some require many additional outputs (garbage). We follow the two-step approach suggested in [9]. First a network for the given function is found. The algorithm for this step is guaranteed to converge. In fact, the algorithm is very fast. Improvements on a naive algorithm are described in [9]. The second step consists of applying transformations which reduce the number of gates. In this paper we describe the templates used for such transformations in detail.

Several authors considered network transformations. Shende *et. al* [12] used several 4-bit circuit equivalencies to be able to rewrite gates in a different order. Their circuit equivalence rules were not proposed for circuit simplification. In our work we cover and classify all templates they describe, generalize the notion of template, and show how to use them to simplify networks. Iwama, Kambayashi, and Yamashita [5] introduced some circuit transformation rules, which mainly served to bring a network to a canonical form and thus, stating that the set of transforms is complete. However, their approach uses a high number of garbage bits, whereas in our approach no garbage is allowed. One of the transforms in [5] was proposed for circuit simplification, but the actual application procedure was not described. Our work generalizes and classifies the templates used by [5], and adds new classes. We also show a way of using templates for network simplification, implemented it, and show results.

2. PRELIMINARIES

An n -input n -output function (gate) is called **reversible** if, and only if, it maps each input instance to a unique output instance. In other words, a reversible function (gate) permutes the elements of its domain. In practice, not all of the $n!$ possible reversible functions can be realized as a single reversible gate. Several reversible gates have been proposed. However, we will only deal with Toffoli gates in this paper.

DEFINITION 1. For the set of domain variables $\{x_1, x_2, \dots, x_n\}$ the **generalized Toffoli gate** has the form $TOF(C, t)$, where $C = \{x_{i_1}, x_{i_2}, \dots, x_{i_k}\}$, $t = \{x_j\}$ and $C \cup t = \emptyset$, and it maps the Boolean pattern $\{x_1^0, x_2^0, \dots, x_n^0\}$ to $\{x_1^0, x_2^0, \dots, x_{j-1}^0, x_j^0 \oplus x_{i_1} x_{i_2} \dots x_{i_k}, x_{j+1}^0, \dots, x_n^0\}$. The set C which controls the change of j -th bit is called the set of **control lines** and t is called the **target**.

In the literature, a subset of all generalized Toffoli gates is

Permission to make digital or hard copies of all or part of this work for personal or classroom use is granted without fee provided that copies are not made or distributed for profit or commercial advantage and that copies bear this notice and the full citation on the first page. To copy otherwise, to republish, to post on servers or to redistribute to lists, requires prior specific permission and/or a fee.

IWLS 2003 Laguna Beach, CA

Copyright 2003 ACM X-XXXXXX-XX-X/XX/XX ...\$5.00.

typically considered. The most popular are: the NOT gate ($TOF(\emptyset, x_j)$), a generalized Toffoli gate which has no controls; the CNOT gate ($TOF(x_i, x_j)$) [3], which is also known as a Feynman gate, a generalized Toffoli gate with one control bit, and the Toffoli gate $TOF(x_{i_1} + x_{i_2}, x_j)$ (where “+” denotes set union) [13], a generalized Toffoli gate with two controls. The three gates are illustrated in Figure 1, and

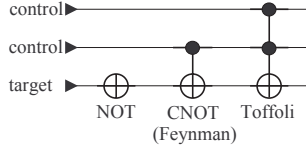

Figure 1: NOT, CNOT and Toffoli gates

the gates with more controls are drawn similarly. Note that the way the gates are drawn is a convention, which is not related to the way the gates are implemented. Gates with more than two controls are discussed in [6]. The set of generalized Toffoli gates is known to be complete (for example, see [7]), in other words, any reversible function can be realized as a cascade of Toffoli gates. A regular synthesis method for Toffoli gate networks is discussed in [9].

Due to probable technological restrictions, the synthesis of reversible logic is done with no feed-back and no fan-out [11]. This leaves the cascade structure as the only model satisfying those conditions. Thus, we consider cascades of Toffoli gates.

Let the signal be propagated from left to right. The pictorial representation of a network is shown in Figure 2. The **cost** of a function is defined as the number of gates in circuit realizing it (S for a network in Figure 2).

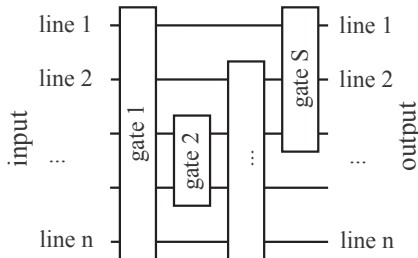

Figure 2: The general structure for a network

3. TEMPLATES

In our previous work [9] we introduced templates as a tool for network simplification. In that work, a template consists of two sequences of gates which realize the same function. The first sequence of gates is to be matched to a part of the circuit being simplified and the second sequence is to be substituted when a match is found. The templates were in Figure 3 were identified and classified based on their similarity.

In [9], the template matching procedure looks for the first set of gates, including the initial match to the widest gate, across the entire circuit. If all target gates are found, it attempts to make them adjacent using the **moving rule**: gate $TOF(C_1, t_1)$ can be interchanged with gate $TOF(C_2, t_2)$ if, and only if, $C_1 \cap t_2 = \emptyset$ and $C_2 \cap t_1 = \emptyset$. Adjacent gates can

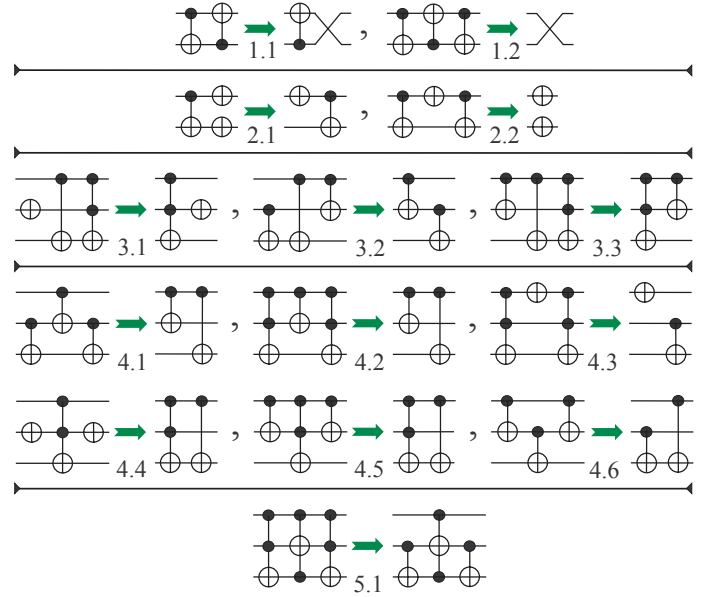

Figure 3: Templates with 2 or 3 inputs.

match the template in the forward or reverse direction. The matched gates are replaced with the new gates specified by the template. For a reverse match, the new gates are substituted in reverse order. Finally, if at any time two adjacent gates are equal, they can be deleted, (**deletion rule**).

In this section, we give a formal classification of the templates used in [9]. However, for a better understanding of template classes, we introduce the following notation.

- the left hand side has a sequence of gates that is to be replaced with the sequence given on the right hand side;
- the controls of the gates are coded by sets C_i each of which represents a set (maybe empty) of lines;
- the target sets t_i each contain a single line.

$$\text{All sets are disjoint: } C_i \cap C_j = \emptyset, C_i \cap t_k = \emptyset, t_l \cap t_k = \emptyset \forall i, j, k, l.$$

Using these notation, a **class** of templates can be defined as a set of templates which can be described by one formula. A first attempt to classify the templates results in the classes listed below:

Class 1. This class unites and generalizes the templates 2.2, 4.1-4.3 (Figure 3) into a class (Figure 4a) with the formula:

$$\begin{aligned} & TOF(C_1 + C_2 + t_2, t_1) TOF(C_1 + C_3, t_2) \\ & TOF(C_1 + C_2 + t_2, t_1) = \\ & = TOF(C_1 + C_3, t_2) TOF(C_1 + C_2 + C_3, t_1) \end{aligned} \quad (1)$$

Class 2. This class consists of templates 4.4-4.6 (Figure 3) and their generalizations. The class is illustrated in Figure 4b and can be written as the following formula:

$$\begin{aligned} & TOF(C_1 + C_2, t_2) TOF(C_1 + C_3 + t_2, t_1) \\ & TOF(C_1 + C_2, t_2) = \\ & = TOF(C_1 + C_3 + t_2, t_1) TOF(C_1 + C_2 + C_3, t_1) \end{aligned} \quad (2)$$

Class 3. This class (Figure 4c) includes templates 2.1, 3.1-3.3 (Figure 3) and can be described by the formula:

$$\begin{aligned} TOF(C_1 + C_2 + t_2, t_1) TOF(C_1 + C_2 + C_3, t_1) \\ TOF(C_1 + C_3, t_2) = \\ = TOF(C_1 + C_3, t_2) TOF(C_1 + C_2 + t_2, t_1) \end{aligned} \quad (3)$$

Template 5.1 can be generalized, but this generalization is not considered here since template 5.1 does not decrease the number of gates in a network. However, use of a generalization of this template may be beneficial since it introduces smaller gates that can be used by other templates. Even if they are not used, it is beneficial to have gates with fewer controls, since for some technologies their costs are lower. For instance, in quantum technology the cost of a Toffoli gate is 7 times higher than that of a CNOT gate [1]. As the number of controls of the Toffoli gate grows, the relation between the costs of generalized Toffoli and CNOT gate grows quadratically if no additional garbage is allowed and linearly if garbage is allowed [1].

The correctness of formulas (1)-(3) is easily proven. A more interesting question is whether the set of these three classes of templates together with the two rules (moving rule, deletion rule) is a complete set of simplification rules for a sequence of three generalized Toffoli gates over n lines. To check this, we ran a program which exhaustively searches all sequences of three gates built on three lines to check whether the sequence can be reduced by means of templates from the three classes and the two rules. This program found no new templates. Thus, we conclude that the three classes together with moving and deletion rules form the complete simplification tool for any Toffoli network with up to three gates.

3.1 Unification of Class 1 and Class 2 Templates

Classes 1 and 2 look similar. This similarity results in the following description of the two classes as one:

- the first part of the template has 3 gates of the form ABA, *i.e.* the first and the third gates are the same;
- if the following algorithm produces a valid network, the template exists, otherwise it does not (correctness can be easily proven):
 - Take the second gate and put it first in the second part of the template.
 - On each line, there may be a logical AND connection (\bullet), an EXOR (\oplus), or no connection with the vertical line (denoted \square). We build the second gate of the right hand side of the template by taking values from Table 1 using the symbols on that line from A and B (since the table is symmetric, there is no need to specify which argument is A and which is B).

	\square	\bullet	\oplus
\square	\square	\bullet	\oplus
\bullet	\bullet	\bullet	\square
\oplus	\oplus	\square	E

Table 1: Second gate building process

- If the symbol E occurs during the building process, the template cannot be built. It is easy to see why, since if all \oplus are on the same line, the moving rule is applicable, and the network can be changed to the form AAB, after which application of deletion rule transforms the network to the form B.
- In other cases, for $TOF(t_1 + t_2, t_3) TOF(t_1 + t_3, t_2) TOF(t_1 + t_2, t_3)$ for example, the algorithm produces logical AND on the first line and nothing at all on the other lines. This makes no sense. That is, no reduction is possible for this sequence of gates.

4. TEMPLATES - A NEW APPROACH

Further we generalize the template tool, but assume the following limitations: the model gates should necessarily be self-inverses. This limits the generality of a template, but for the goals of the current paper this does not change the essence, since generalized Toffoli gate is a self-inverse.

Although the template description in Section 3 is formal and shorter (3 classes and 2 rules in comparison to 14 templates with 2 rules as used before), it can be simplified even further. For this we need a new understanding of templates.

Let a **size m template** be a sequence of m gates (a circuit) which realizes the identity function. Any template of size m must be independent of templates of smaller size, *i.e.* for a given template size m no application of any set of templates of smaller size can decrease the number gates. The template $G_0 G_1 \dots G_{m-1}$ can be applied in two directions:

1. **Forward application:** A piece of network that matches the sequence of gates $G_i G_{(i+1) \bmod m} \dots G_{(i+k-1) \bmod m}$ of the template $G_0 G_1 \dots G_{m-1}$ exactly, is replaced with the sequence $G_{(i-1) \bmod m} G_{(i-2) \bmod m} \dots G_{(i+k) \bmod m}$ without changing the network's output, where $k \in N, k \geq \frac{m}{2}$.
2. **Backward application:** A piece of network that matches the sequence of gates $G_i G_{(i-1) \bmod m} \dots G_{(i-k+1) \bmod m}$ exactly, is replaced with the sequence $G_{(i+1) \bmod m} G_{(i+2) \bmod m} \dots G_{(i+k) \bmod m}$ without changing the network output, where $k \in N, k \geq \frac{m}{2}$.

These definitions of template application need a correctness proof—the network output should not be changed for each of the listed operations. Correctness can be verified as follows. Note, that a reversible cascade that realizes a function f read in reverse (from the outputs to the inputs) realizes f^{-1} , its inverse.

First, we prove the correctness of the forward application of a template starting with element G_0 . The operation for this case requires substitution of $G_0 G_1 \dots G_{k-1}$ with $G_{m-1} G_{m-2} \dots G_k$. Since $G_0 G_1 \dots G_{m-1}$ realizes the identity function, $G_k G_{k+1} \dots G_{m-1}$ realizes the inverse of the function realized by $G_0 G_1 \dots G_{k-1}$. Therefore, read in reverse order $G_k G_{k+1} \dots G_{m-1}$ realizes inverse of the inverse, *i.e.* the function itself. Thus, the function realized by $G_0 G_1 \dots G_{k-1}$ was substituted by itself, which does not change the output of the network. Correctness of the remaining forward applications can be proven by using Lemma 1.

Correctness of all reverse applications follows from the proof above and from the observation that the inverse of

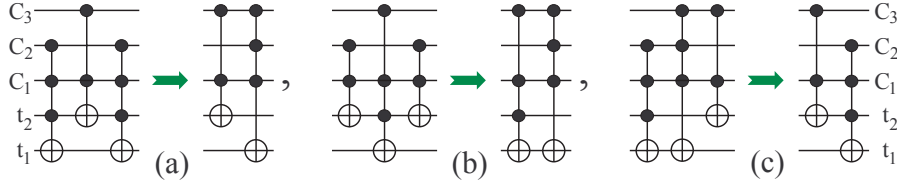

Figure 4: Toffoli templates.

the identity function is the identity function.

Next, observe that a template can be used in both directions, forward and backward as the formulas show. Also, we can start using it from any element. Thus, it is better to think of a template as a cyclic sequence. The correctness of viewing a template as a cyclic sequence is proven with the following Lemma.

LEMMA 1. *If a network $G_0 G_1 \dots G_{m-1}$ realizes the identity function, then for any k -shift, $G_k G_{(k+1) \bmod m} \dots G_{(k-1) \bmod m}$ realizes the identity.*

PROOF. We prove the Lemma for 1-shift, $G_1 G_2 \dots G_{m-1} G_0$. Then all k -shifts can be proven by applying the 1-shift k times. The proof for a 1-shift follows from:

$$\begin{aligned} Id &= G_0 G_1 \dots G_{m-1} \\ G_0 Id &= G_0 G_0 G_1 \dots G_{m-1} \\ G_0 &= G_1 G_2 \dots G_{m-1} \\ Id &= G_0 G_0 = G_1 G_2 \dots G_{m-1} G_0. \end{aligned}$$

□

The condition $k \geq \frac{m}{2}$ is used as we do not want to increase the number of gates when a template is applied and equality yields a simpler classification scheme.

The following is a classification of templates up to size 7. We use the notation introduced in the previous section.

- $m=1$. Size 1 templates do not exist, since each generalized Toffoli gate produces a change of its input.
- $m=2$. There is one class of templates of size 2 (Figure 5a), and it is the deletion rule which is described by the sequence (AA)

$$TOF(C_1, t_1) TOF(C_1, t_1).$$

- $m=3$. There are no templates of size 3.
- $m=4$. There is one class of templates (Figure 5b), the moving rule from the previous section, which can be written as follows (ABAB):

$$\begin{aligned} &TOF(C_1 + C_2, C_4 + C_5) TOF(C_1 + C_3, C_4 + C_6) \\ &TOF(C_1 + C_2, C_4 + C_5) TOF(C_1 + C_3, C_4 + C_6). \end{aligned}$$

The set notation is used to describe the targets since they may intersect or not, which is impossible to describe in one formula using the t_i notation for the targets. The upper template in Figure 5b has $|C_4| = 0$ which results in $|C_5| = 1$ and $|C_6| = 1$, when the lower has $|C_4| = 1$ resulting in $|C_5| = 0$ and $|C_6| = 0$.

- $m=5$. Surprisingly, there is only class of template of size 5 (Figure 5c), which unites the three earlier classes

(1)-(3) and includes templates 2.1-2.2, 3.1- 3.3 and 4.1-4.6 from Figure 3. The class can be written as (ABABC):

$$\begin{aligned} &TOF(C_1 + C_2 + t_2, t_1) TOF(C_1 + C_3, t_2) \\ &TOF(C_1 + C_2 + t_2, t_1) TOF(C_1 + C_3, t_2) \\ &TOF(C_1 + C_2 + C_3, t_1). \end{aligned}$$

- $m=6$. There are two classes here (Figure 5d), and they are described by formulas (ABACBC)

$$\begin{aligned} &TOF(C_1 + t_2, t_1) TOF(C_1 + C_2 + C_3 + t_1, t_2) \\ &TOF(C_1 + t_2, t_1) TOF(C_1 + C_2 + t_2, t_1) \\ &TOF(C_1 + C_2 + C_3 + t_1, t_2) TOF(C_1 + C_2 + t_2, t_1) \end{aligned}$$

and (ABACDC)

$$\begin{aligned} &TOF(C_1 + t_2, t_1) TOF(C_1 + C_2 + C_3 + t_1, t_2) \\ &TOF(C_1 + t_2, t_1) TOF(C_1 + C_2 + t_1, t_2) \\ &TOF(C_1 + C_2 + C_3 + t_2, t_1) TOF(C_1 + C_2 + t_1, t_2). \end{aligned}$$

Note, the two formulas for the classes look very similar, and, in fact using Fredkin gates, they can be generalized to form one very simple template $FRE(C_1 + C_2 + C_3, t_1 + t_2) FRE(C_1 + C_2 + C_3, t_1 + t_2)$ (where $FRE(C, t_1 + t_2)$ is a gate which swaps values of bits t_1 and t_2 if, and only if, set C has all ones on its lines), but we do not pursue this here as we are restricting our attention to generalized Toffoli gates.

- $m=7$. There are no templates of size 7.

For $m > 7$, the number of templates is expected to grow very fast (exponentially). One way to reduce the number of templates is to allow Fredkin gates.

To verify the correctness of the above classification, we must show that no template of larger size can be reduced to a template of smaller size.

Templates of size 4. The templates are independent of the size 2 template, since no adjacent gates are equal.

Template of size 5.

- The template is independent of the size 2 template, since no adjacent gates are equal.
- The size 4 template can be applied to move gate C anywhere in a template, but it does not allow any simplification of a size 5 template by smaller templates.

Templates of size 6.

- Size 6 templates are independent of the size 2 template, since no adjacent gates are equal.
- A size 4 template can be applied to interchange gates A and C of template ABACBC only and does not lead to any simplification.

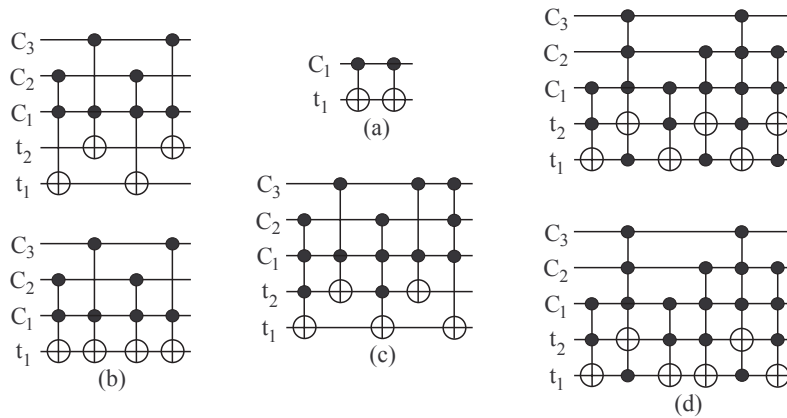

Figure 5: All templates for $m \leq 7$.

- The size 5 template matches at most 2 gates of template ABACBC, and therefore can not be applied.

4.1 Completeness

First of all, we wrote a program which builds all the 4-input 4-output circuits of size 7 that realize the identity function and tries to apply the templates. The program result shows that the set of our 5 templates (AA, ABAB, ABABC, ABACBC, ABACDC) is the complete set of templates of size 7 or less for 4 inputs and less.

The mathematical proof of completeness of this set for any number of inputs is harder. For templates of size 2 it can be done by hand, since there are not so many choices to look at. For templates of size 4 and 5 the following lemmas are useful.

LEMMA 2. *A size m template has at most $\lfloor \frac{m}{2} \rfloor$ different lines with EXOR signs.*

PROOF. Prove by contradiction. Suppose there are $\lfloor \frac{m}{2} \rfloor + 1$ or more lines which contain EXOR sign. Then, by the pigeon hole principle, there will be one line with one EXOR sign only. Cut the cycle so that the gate with this EXOR, $TOF(C, t)$ comes first. Now, if we assign 1 to all $x_j \in C$, the value of t changes to \bar{t} as the signal is propagated in the template. Thus, the template does not realize the identity function, which contradicts its definition. \square

LEMMA 3. *Given a template of size m where all gates have the same target line (i.e. the EXOR appears on a single line), then m is even and all gates can be grouped as pairs of equal gates.*

PROOF. Proof by contradiction. Suppose not all the gates can be paired or the number m is odd. Apply passing and duplication deletion rules to delete all the paired gates from the template. The remaining circuit still realizes the identity since all the applied operations did not change the circuit output. When propagate the signal in the network, the output on the line with EXOR (for instance, x_n) becomes a polynomial of a positive polarity on the remaining variables (for instance, x_1, x_2, \dots, x_{n-1}). In other words, Zhegalkin polynomial on the set of variables $\{x_1, x_2, \dots, x_{n-1}\}$ was added to the input x_n . Since no non-zero Zhegalkin polynomial equals zero, the output on n -th line will differ from its input. This contradicts the definition of a template since it is supposed to realize identity function. \square

Use of Lemma 2 allows us to say that all the templates of size 4 have EXOR signs on either two lines (two signs on one and two on the other) or 1 line (all 4 on 1 line). In the last case use Lemma 3. Thus, an exhaustive search proof becomes reasonable. For the size 5 templates we can guarantee that they all will have exactly two lines with EXOR. Note, that Lemma 3 proves that the only two templates which have only one line affected with EXOR are the duplication deletion rule and the passing rule, all other identities of this type are applications of the above rules.

5. EXPERIMENTAL RESULTS

We wrote programs to verify the correctness of our results, build the new templates and apply them. The results of the verification program were discussed in above.

The program which simplifies the networks works as follows. First, it is convenient to store template ABAB as a separate rule which helps to bring the gates together to match a template. Then, the circuit is simplified as follows. We call this the “moving rule”. For the hierarchy of templates $AA \succ ABABC \succ ABACBC \succ ABACDC$ try to match as many gates of a template as possible by looking ahead in the network and using the moving rule. If a template can be applied, apply it for the greatest application parameter k possible. After applying any template start trying to apply the templates in hierarchical order from the very beginning. If none of the templates can be applied, the simplification process stops.

EXAMPLE 1. *We took a network for three bit adder produced by the synthesis algorithm presented in [9] (Figure 6) and applied our program to simplify it. As expected, the program used a size 5 template and matched 3 gates. Thus, they were substituted by the remaining 2 gates of the template read in reverse order. This circuit is optimal, since no further reduction is possible. Suppose, an adder can be realized with 3 gates or less. Then, addition of these gates to the end of the built size 4 cascade results in a new template which was proven (by enumeration) not to exist for size 7 and less and four inputs.*

6. CONCLUSION

The larger the set of templates, the more reductions can be done. For instance, if for some natural number k

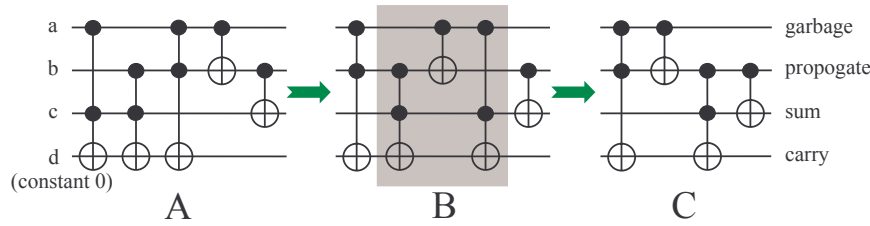

Figure 6: Optimal circuit for a full adder.

optimality is defined as the impossibility of simplifying a network with size $2k - 1$ and less templates, then all the templates of size $n * 2^{n+1} - 1$ and less form the complete simplification tool for the synthesis method provided in [9]. The theoretical algorithm from [9] produces a valid network with at most $n * 2^n$ gates, therefore if this network is not optimal and was not simplified by all templates with size $n * 2^{n+1} - 1$ and less, not all the templates are listed. Thus, we come to a contradiction which proves the statement.

In this work we built the set of templates and showed a procedure allowing us to create 4-optimal circuits for networks with number of inputs less than or equal to 4. We generalized these templates and proposed them as the set of rules which produces a 4-optimal network out of those given. The template tool was generalized and shown in a readily usable form.

7. REFERENCES

- [1] A. Barenco, C. H. Bennett, R. Cleve, D. P. DiVincenzo, N. Margolus, P. Shor, T. Sleator, J. A. Smolin, and H. Weinfurter. Elementary gates for quantum computation. *The American Physical Society*, (52):3457–3467, 1995.
- [2] G. W. Dueck and D. Maslov. Reversible function synthesis with minimum garbage outputs. In *6th International Symposium on Representations and Methodology of Future Computing Technologies*, pages 154–161, March 2003.
- [3] R. Feynman. Quantum mechanical computers. *Optic News*, 11:11–20, 1985.
- [4] E. Fredkin and T. Toffoli. Conservative logic. *International Journal of Theoretical Physics*, 21:219–253, 1982.
- [5] K. Iwama, Y. Kambayashi, and S. Yamashita. Transformation rules for designing cnot-based quantum circuits. In *Proceedings of the Design Automation Conference*, New Orleans, Louisiana, USA, June 10-14 2002.
- [6] D. Maslov and G. Dueck. Asymptotically optimal regular synthesis of quantum networks. In *International Workshop on Logic Synthesis*, Laguna Beach CA, 2003.
- [7] D. Maslov and G. W. Dueck. Garbage in reversible design of multiple output functions. In *6th International Symposium on Representations and Methodology of Future Computing Technologies*, pages 162–170, March 2003.
- [8] D. M. Miller and G. W. Dueck. Spectral techniques for reversible logic synthesis. In *6th International Symposium on Representations and Methodology of Future Computing Technologies*, March 2003.
- [9] D. M. Miller, D. Maslov, and G. W. Dueck. A transformation based algorithm for reversible logic synthesis. In *Proceedings of the Design Automation Conference*, June 2003.
- [10] A. Mishchenko and M. Perkowski. Logic synthesis of reversible wave cascades. In *International Workshop on Logic Synthesis*, June 2002.
- [11] M. Nielsen and I. Chuang. *Quantum Computation and Quantum Information*. Cambridge University Press, 2000.
- [12] V. V. Shende, A. K. Prasad, I. L. Markov, and J. P. Hayes. Reversible logic circuit synthesis. In *ICCAD*, pages 125–132, San Jose, California, USA, Nov 10-14 2002.
- [13] T. Toffoli. Reversible computing. *Tech memo MIT/LCS/TM-151, MIT Lab for Comp. Sci*, 1980.